



Patent #6,253,416 and other patents pending
F601S, F601HS

BILLY GOAT FORCE BLOWER Owner's Manual

ACCESSORIES

FRONT AIR DIRECTOR
<i>Simple to attach, allowing air to be directed forward.</i>

PN# 441130

HOSE KIT
<i>Easily attached hose and nozzle for hard to reach places.</i>

PN# 441166



CONTENTS

SPECIFICATIONS/ SOUND AND VIBRATION	3
INSTRUCTION LABELS	4
PACKING CHECKLIST	5
ASSEMBLY	6
OPERATION AND MAINTENANCE	7
TROUBLESHOOTING	8
ILLUSTRATED PARTS LIST	9
PARTS LIST	10

Go to <http://www.billygoat.com> for French-Canadian translations of the product manuals.

Visitez <http://www.billygoat.com> pour la version canadienne-française des manuels de produits



FORCE 6 BLOWER Owner's Manual

Specifications

F601S

F601HS

Engine: HP	6.0 HP (4.7kW)	6.0 HP (4.7kW)
Engine: Model	SP170DP0166	GS190AQBA
Engine: Type	SUBARU	HONDA
Engine: Fuel Capacity	3.8 qt.(3.6 L)	1.9 qt. (1.8 L)
Engine: Oil Capacity	0.63 qt.(0.60 L)	0.63 qt. (0.6L)
Total Unit Weight:	76# (34.5 kg)	76# (34.5 kg)
Overall Length:	43.5"(1.1m)	43.5"(1.1m)
Overall Width	22" (0.56m)	22" (0.56m)
Overall Height	45" (1.14m)	45" (1.14m)
Max operating slope	20°	20°
In compliance with 2000/14/EEC standards	105dB(a) @3600 rpm	105dB(a) @3600 rpm
Sound at Operator's ears	89dB(a) @ 3600 rpm	89dB(a) @ 3600 rpm
Vibration at operator position	1.02 g (10.1 m/s ²)	1.02 g (10.1 m/s ²)

SOUND



L_{WA}
105

SOUND LEVEL 89 Db(a) at Operators Position

Sound tests were conducted in accordance with 2000/14/EC, as well as ISO 11094, and were performed on 8-3-2007 under the conditions listed below.

Sound power level listed is the highest value for any model covered in this manual. Please refer to serial plate on the unit for the sound power level for your model.

General Conditions:
 Temperature:
 Wind Speed:
 Wind Direction:
 Humidity:
 Barometric Pressure:

Sunny
 87.8°F (31.1°C)
 1.8 mph (2.8kph)
 East South east
 61.5%
 30.1Hg (101.98kpa)

VIBRATION DATA

VIBRATION LEVEL 1.02g (10.1m/s²)

Vibration levels at the operator's handles were measured in the vertical, lateral and longitudinal directions using calibrated vibration test equipment. Tests were performed on 9-20-07 under the conditions listed below.

General Conditions:
 Temperature:
 Wind Speed:
 Wind Direction:
 Humidity:
 Barometric Pressure:

Sunny
 86.5°F (30.3°C)
 8 mph (13 kph)
 South Southwest
 49.8%
 30.1Hg (101.94kpa)



FORCE 6 BLOWER Owner's Manual

INSTRUCTION LABELS

The labels shown below were installed on your BILLY GOAT[®] FORCE Blower. If any labels are damaged or missing, replace them before operating this equipment. Item numbers from the Illustrated Parts List and part numbers are provided for convenience in ordering replacement labels. The correct position for each label may be determined by referring to the Figure and Item numbers shown.



LABEL SPARK ARRESTOR
P/N 100252



LABEL READ OWNERS MANUAL
ITEM #35 P/N890301

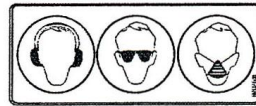

LABEL EAR EYE BREATHING
ITEM#36 P/N890254



DANGER FLYING DEBRIS
ITEM # 37 P/N 810736

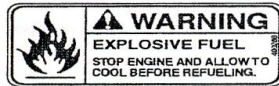

LABEL EXPLOSIVE FUEL
ITEM # 34 P/N 400268

ENGINE LABELS

SUBARU

	Read the owner's manual.		
	Stay clear of the hot surface.		
	Exhaust gas is poisonous. Do not operate in an unventilated area.		
	Stop the engine before refueling.		
	Fire, open flame and smoking prohibited.		
	On (Run)	+	Plus; Positive polarity
○	Off (Stop)		Battery
	Engine oil		Engine start (Electric start)
	Add oil		



HONDA

■ READ OWN'S MANU BEFORE OPEION
 ■ LIRE LE MAND UTILIÆEURANT USAG
 ■ VOR INBETRIEBNAHME UNBEDINGHT BEDIENUNGSANLEITL
 ■ NO UTILIZAR SINANTES NO HABEMANUA
 HONDA MOTOR CO., LTD. MADE IN JAPAN





PACKING CHECKLIST

These items should be included in your carton. If any of these parts are missing, contact your dealer.
Your BILLY GOAT® *FORCE Blower* was shipped in one carton, completely assembled except for the Upper Handle Assembly and Front Diverter. Mounting hardware for the Upper Handle Assembly can be found on the lower handle.



READ all safety instructions before assembling unit.

TAKE CAUTION when removing the unit from the box the Handle Assembly is attached to the unit by cables.



PUT OIL IN ENGINE BEFORE STARTING

**PARTS BAG &
LITERATURE ASSY**

Warranty card P/N- 400972, Owner's Manual P/N-441242, General Safety and Warnings Manual P/N-100294. Declaration of Conformity P/N-440022



Boxing Parts Checklist

- Handle Upper Assembly
Item #24 P/N-441157
- Parts Bag & Literature Assy
P/N-441160
- Subaru 6
- Honda 6

ASSEMBLY

1. Follow the steps in figures A and B, then securely tighten all hardware shown.
2. Connect spark plug wire.

Figure A

The hardware for attaching the upper handle to the lower can be found on the lower handle. Install upper handle (item 24), to preassembled lower handles (item 25 & 26) by sliding the upper over and down the inside of the lower handle. Using bolt (item #12), washers (item #10) & lock nut (item #11) to install upper handle to lower handle. Finish installing the other side of the upper handle assembly using screw and lock nut provided. The Aim-and-Shoot™ is not attached, you will need to unroll the cable and attach the ball end to the lever and seat the cable end into the hole on the saddle clamp, with the cable running through the slot. To keep the cable from being damaged use three ty-wraps (item 61) to secure it to the handle, as shown making sure that the cable is not rubbing against the tire.

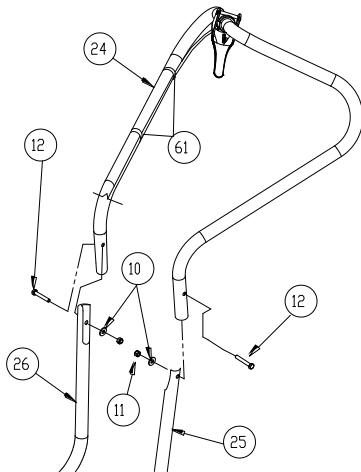

Two 1/2" open ended wrenches

Figure B

Attach the front tire using the hardware located on the front wheel bracket. Use a block to raise the front end of the unit off the ground. Insert the wheel spacer (item 17) into the wheel and place in between the bracket. Finally insert the bolt (item 20) through the bracket, wheel, and spacer and secure with the nut (item 27)

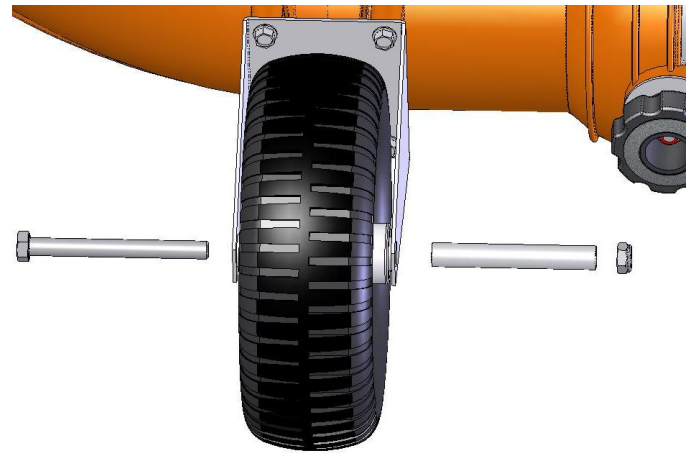

Two 9/16" Wrenches



BLOWING OPERATION

Your Billy Goat Force blower is equipped with an air director cone and the patented Aim-N-Shoot™ control lever to allow the operator to direct the air stream up or down as required to assist in moving debris. This feature is extremely useful when debris has piled up to the point that it cannot be blown any farther. The air stream can be directed upward to blow the top of the debris pile over and allow the operator to continue moving more debris farther.

ADJUSTING AIR DIRECTOR

To adjust air direction, squeeze Aim-N-Shoot™ control lever. When you want to blow debris at the same angle for an extended period, choose a suitable position and use the finger controlled push button lock to lock the cone in position. For operations that do not require the use of the Aim-N-Shoot™ feature the manual adjustment knob, pictured below, can be used to permanently lock the cone into position. NOTE: be sure to release the knob when returning to using the Aim-N-Shoot™.

⚠ DO NOT position director cone to where it will blow debris towards people, vehicles or other objects in vicinity. Flying debris may damage, harm, or cause injury to people or objects in air flow range.

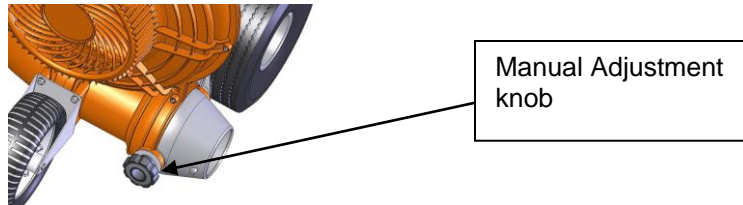

PERIODIC MAINTENANCE

Periodic maintenance should be performed at the following intervals:

Maintenance Operation	Every Use	Daily or Every 5 Hours	Every 25 Hours	Every 50 Hours	Every 100-150 Hours
Inspect for worn or damaged parts.	•				
Check for excessive vibration		•			
Inspect Impeller for cracks or damage					•
Inspect for loose parts.		•			

IMPELLER REMOVAL

1. Wait for engine to cool and disconnect spark plug.
2. Remove housing front cover, by removing (10) screws, around outside of front cover and the exhaust knob (22) and nut(14)
3. Remove impeller bolt (item #29), lock washer (item #7) and washer (item #28).
4. **DO NOT** pry on impeller. Pull on center hub area only of impeller. If impeller slides off freely, proceed to (step 6).
5. If the impeller does not loosen, use a pry bar against the back of the hub and the plate and apply pressure to separate the impeller from the shaft. **DO NOT** use the pry bar to apply pressure to any plastic part such as the impeller or the main housing. *Using a penetrating oil can help loosen a stuck impeller.*
6. Reinstall new impeller in reverse order of removal.
7. Tighten impeller bolt. Torque impeller bolt (see parts list on page 10 for proper impeller bolt torque specifications).

TIRE AIR PRESSURE

Check at regular intervals and maintain.
Rear Tires - 20 Psi (137 kPa).



TROUBLESHOOTING

Problem	Possible Cause	Solution
Abnormal vibration.	<ul style="list-style-type: none">Loose or out of balance impeller.Debris in impeller.Loose engine.	<ul style="list-style-type: none">Check impeller and replace if required.Clear debris with compressed air or a backpack blower (see below pictures).*Check engine.
Engine will not start.	<ul style="list-style-type: none">Engine not in full choke position.Out of gasoline or bad, old gasoline.Spark Plug wire disconnected.Gas valve off.Dirty air cleaner.	<ul style="list-style-type: none">Check choke position.Check gasoline.Connect spark plug wire.Turn on gas valve.Clean or replace air cleaner. Contact a qualified service person.
Engine is locked, will not pull over.	<ul style="list-style-type: none">Engine problem.	<ul style="list-style-type: none">Contact an engine servicing dealer for engine problems.
Aim-N-Shoot™ lever sticking	<ul style="list-style-type: none">Debris stuck around coneCone adjustment knob too tightAdaptor mount nut (item 43) too tight	<ul style="list-style-type: none">Clean debrisApply silicone based lubricant to pivot pointsLoosen manual adjustment knobLoosen nut

*Using compressed air, or a Backpack blower, you can loosen or free debris easily from the impeller and housing, which can cause wear and tear on the machine. You can manually remove debris by taking off the front housing. Note: Always disconnect the sparkplug when servicing.

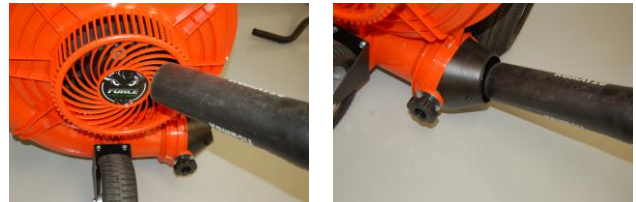

ILLUSTRATED PARTS LIST

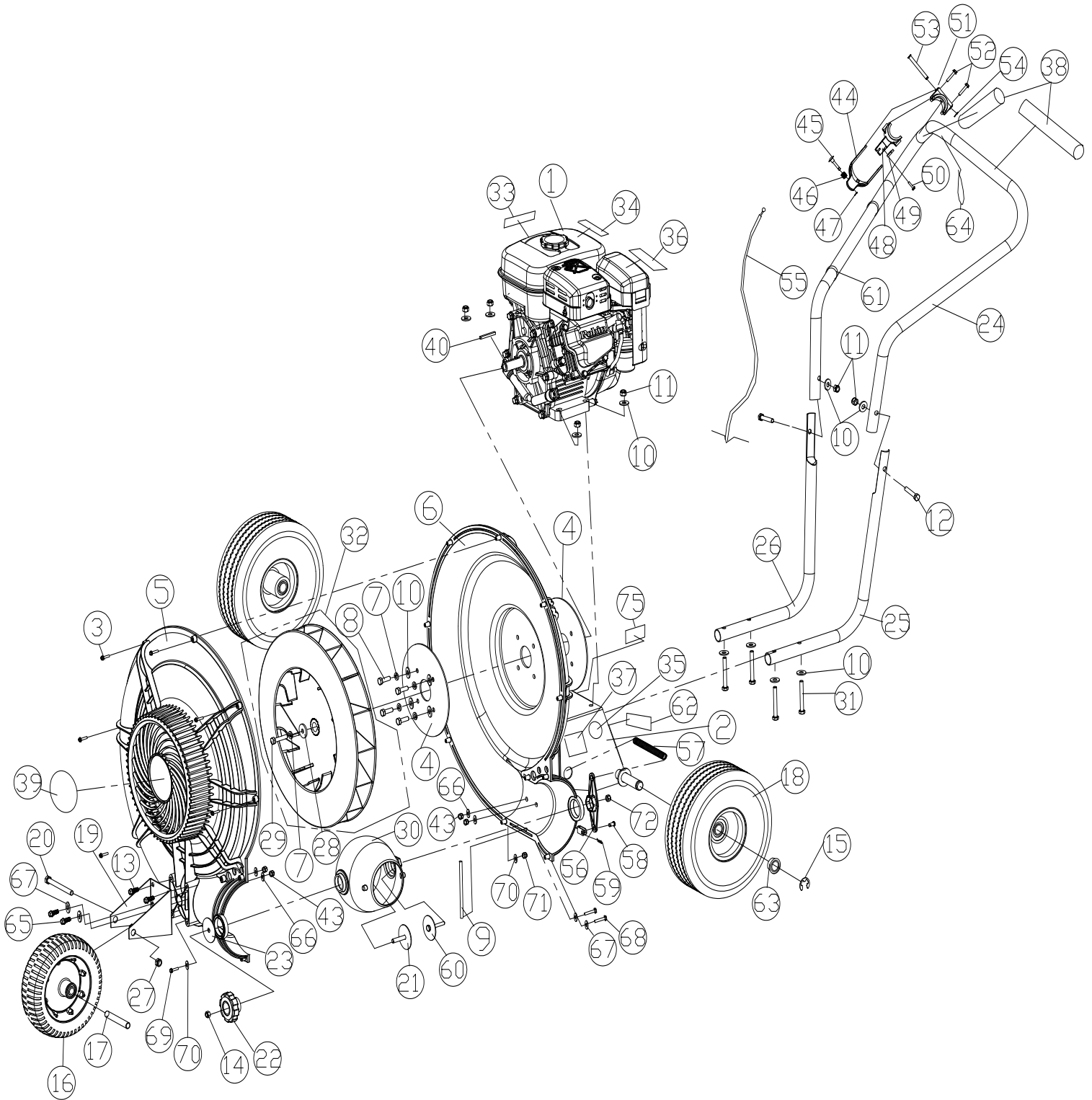



FORCE 6 BLOWER Owner's Manual

PARTS LIST

ITEM NO.	DESCRIPTION	F601S		F601HS	
		PART NUMBER	QTY.	PART NUMBER	QTY.
1	ENGINE 6 HP HORZ SUBARU	350307	1	-	-
	ENGINE 6 HP HONDA	-	-	441199	1
2	BASE ENGINE WA	441151-S	1	441151-S	1
3	SCREW PLASTITE #8-16 X 3/4" HWH	441155	10	441155	10
4	PLATE REINFORCE HOUSING	441102	2	441102	2
5	HOUSING FRONT MOLDED	441101-1-S	1	441101-1-S	1
6	HOUSING BACK MOLDED	441101-2	1	441101-2	1
7	WASHER LOCK 5/16 ST MED	8177011	5	8177011	5
8	SCREW CAP 5/16-24 X 1" GR. 5 ZP	400164	4	400164	4
9	ROD HAND STOP	441154	1	441154	1
10	WASHER 5/16 FLATWASHER Z/P	8171003	14	8171003	14
11	NYLON INSERT LOCKNUT 5/16-18	8160002	6	8160002	6
12	SCREWCAP 5/16-18 X 1.75 ZP	8041031	2	8041031	2
13	SCREW PLASTITE 1/4-10 X 3/4 HWH	840082	4	840082	4
14	NUT LOCK 5/16-18 LT WT TH ZP	8161041	1	8161041	1
15	RING RETAINING 3/4	850230	2	850230	2
16	WHEEL 8" X 0.5	441123	1	441123	1
17	SPACER FRONT AXLE	441162	1	441162	1
18	WHEEL ASSY 10"	400295	2	400295	2
19	FRONT WHEEL BRACKET	441122	1	441122	1
20	SCREWCAP 3/8-16 X 3 3/4 HCS ZP	8041061	1	8041061	1
21	WASHER W/BOLT WA	441156	1	441156	1
22	KNOB 5/16-18 X 5/8 FLUTED	400339	1	400339	1
23	WASHER EXTENSION	810652	1	810652	1
24	HANDLE UPPER	441157-S	1	441157-S	1
25	HANDLE LOWER LH	441158	1	441158	1
26	HANDLE LOWER RH	441159	1	441159	1
27	NUT LOCK 3/8-16 LT WT THIN ZP	8161042	1	8161042	1
28	WASHER 1.125 OD X 0.344 ID X 10 GA.	441150	1	441150	1
29	SCREWCAP 5/16-24 X 1 1/2 GR 8 24-28 Ft. lbs. (33-38 N.m.)	830135	1	830135	1
30	DIRECTOR CONE 3.5"	441120-01	1	441120-01	1
31	SCREWCAP 5/16-18 X 2 1/2	8041034	4	8041034	4
32	IMPELLER ASSEMBLY 16"	441202-S	1	441202-S	1
33	LABEL SPARK ARRESTOR	100252	1	100252	1
34	LABEL WARNING FUEL EN/SP	100261	1	100261	1
35	LABEL READ	890301	1	890301	1
36	LABEL EAR EYE BREATHING	890254	1	890254	1
37	LABEL DANGER FLYING DEBRIS	810736	1	810736	1
38	GRIP 1" ID x 13"	400570	2	400570	2
39	LABEL LOGO SMALL FRAME	441234	1	441234	1
40	Key 3/16" SQ x 1 3/4	9201084	1	9201084	1
43	NUT LOCK 1/4"-20 HEX ZP	8160001	4	8160001	4
44	HANDLE DIVERTER FORCE	440119	1	440119	1
45	PIN LATCH DIVERTER	440118	1	440118	1
46	SPRING COMPRESSION .0281 X 0.88	440129	1	440129	1
47	RING RETAINING .122 DIA	440125	1	440125	1
48	SADDLE LOWER DIVERTER	440115	1	440115	1
49	PLATE LOCK DIVERTER	440116	1	440116	1
50	SCREW PLASTITE #6-19 X 5/8"	440132	1	440132	1
51	SADDLE UPPER DIVERTER	440114	1	440114	1
52	SCREW PLASTITE #10-14 X 1"	440126	2	440126	2
53	PIN PIVOT DIVERTER CONTROL	440123	1	440123	1
54	RING RETAINING 5/16	430327	1	430327	1
55	CABLE ASSY	441163	1	441163	1
56	DIVERTER PIVOT ADAPTOR	440121	1	440121	1
57	SPRING EXTENSION 0.468 X 5.25	440130	1	440130	1
58	PIN CLEVIS 1/4 X 3/4	440124	1	440124	1
59	.051 X 3/4" HITCH PIN CLIP	440193	1	440193	1
60	ADAPTOR MOUNT WA	440122	1	440122	1
61	TY-WRAP	900407	3	900407	3
62	LABEL VIBRATION WARNING	440191	1	440191	1
63	FORCE WHEEL BEARING .751 ID	440055	2	440055	2
64	ELASTIC LOOP BLACK 5.5"	100267	1	100267	1
65	SCREWCAP 1/4-20 X 1 1/4" HCS ZP	8041007	2	8041007	2
66	FENDER WASHER 5/16	8172020	4	8172020	4
67	WASHER 1/4" SAE	8172007	4	8172007	4
68	SCREWCAP 1/4"-20 1 1/2" HCS ZP	8041008	2	8041008	2
69	SCREWCAP #10-24 X 1 1/4" HWH ZP	8059140	1	8059140	1
70	WASHER #10 SAE	8172005	2	8172005	2
71	NUT LOCK LT #10 - 24 HEX	8164005	1	8164005	1
72	NUT LOCK 1/4"-20 2 WAY	8142004	1	8142004	1
75	LABEL MADE IN U.S.A.	520116	1	520116	1